

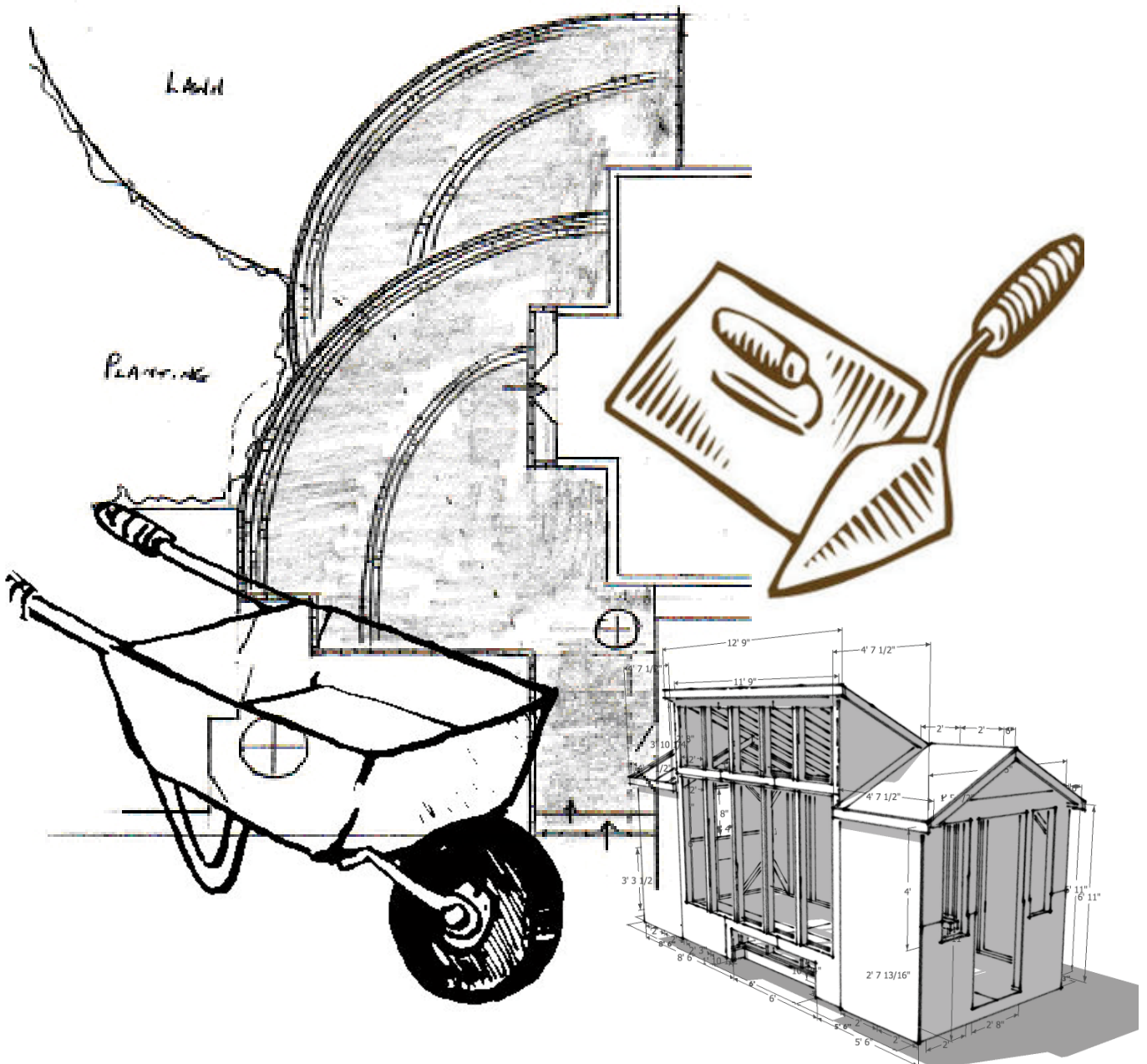

# Melbourne Brick

Turning your outdoor dreams into a dream outdoors

# DIY Paving



## Laying Pavers - Step by step guide

Turn your vision into a picture by following this easy step by step guide to easy paving. Use our easy calculation tables to calculate your requirements

### Safety Tips

Check your equipment ensure that you read the operating manuals of all equipment including hired equipment such as plate compactors and cutting equipment.

Check the condition of hand tools such as mallets etc. to make sure they are in safe working order before use. Always operate equipment according to the manufacturers instructions and wear all the appropriate safety clothing and eye protection listed by the manufactures.

## Laying Pavers - Step by step guide

Turn your vision into a picture by following this easy step by step guide to easy paving. Use our easy calculation tables to calculate your requirements

### Check List

#### Pavers

Spade, rake (metal prongs), wheelbarrow, wooden stakes, string line, tape measure, pegs and spirit level

Mechanical plate compactor (available from plant and hire store consult your supplier for weight requirements).

Piece of carpet or rubber mat (to protect pavers when compacting)

#### Bedding sand

(recommended: coarse washed river sand)

#### Base layer

(Generally: road base material, as found in your local sand and soil supply store or well crushed rock).

#### Screeding rails

(e.g. 2 pieces of timber, approximately 3m long and 30-40mm thick)

#### Screeding board

(e.g. a flat straight piece of aluminum or timber, approximately 3m long)

#### Spirit level

available from hardware stores

#### Jointing sand

(Recommended: fine washed sand)

Sand and cement for edge restraints

Rubber mallet and hardwood plank (for small jobs only)

Paver cutting equipment (e.g. brick saw or bolster available from plant hire store)

Refer to Safety Tips

## Laying Pavers - Step One

### Planning your Project

You will need to plan every aspect of your job before jumping in and getting started. This will save you time and money and will ensure that the end result is as you imagine it to be.

### Planning will tell you:

- The pattern
- The number of pavers and how many cuts will be required
- How much material will be required
- What equipment you will need

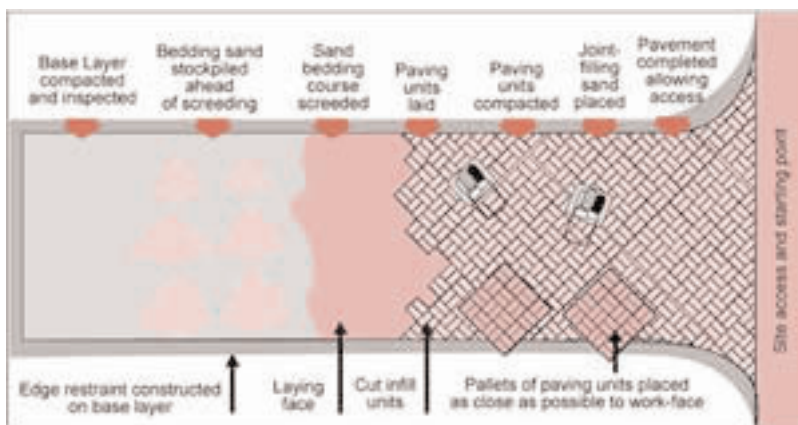

## Laying Pavers - Step Two

### Draw a Plan

An accurate plan, drawn to scale will provide you with an great tool for calculating your requirements.

A plan of the area to be paved should be drawn accurately. Use the planning grid (next page) to help develop your landscaping ideas.

Mark out on site with a piece of string or chalk for an even clearer idea of how your paving will look.

Don't forget to provide for storm water runoff along with the required utilities that need to run under the paved area, such as storm water pipes, water pipes for a sprinkler system and electrical wiring for external power points needed for ponds, fountains and lighting.

If further work is required around the site, such as retaining walls, check that access will be available after the paving has been completed.

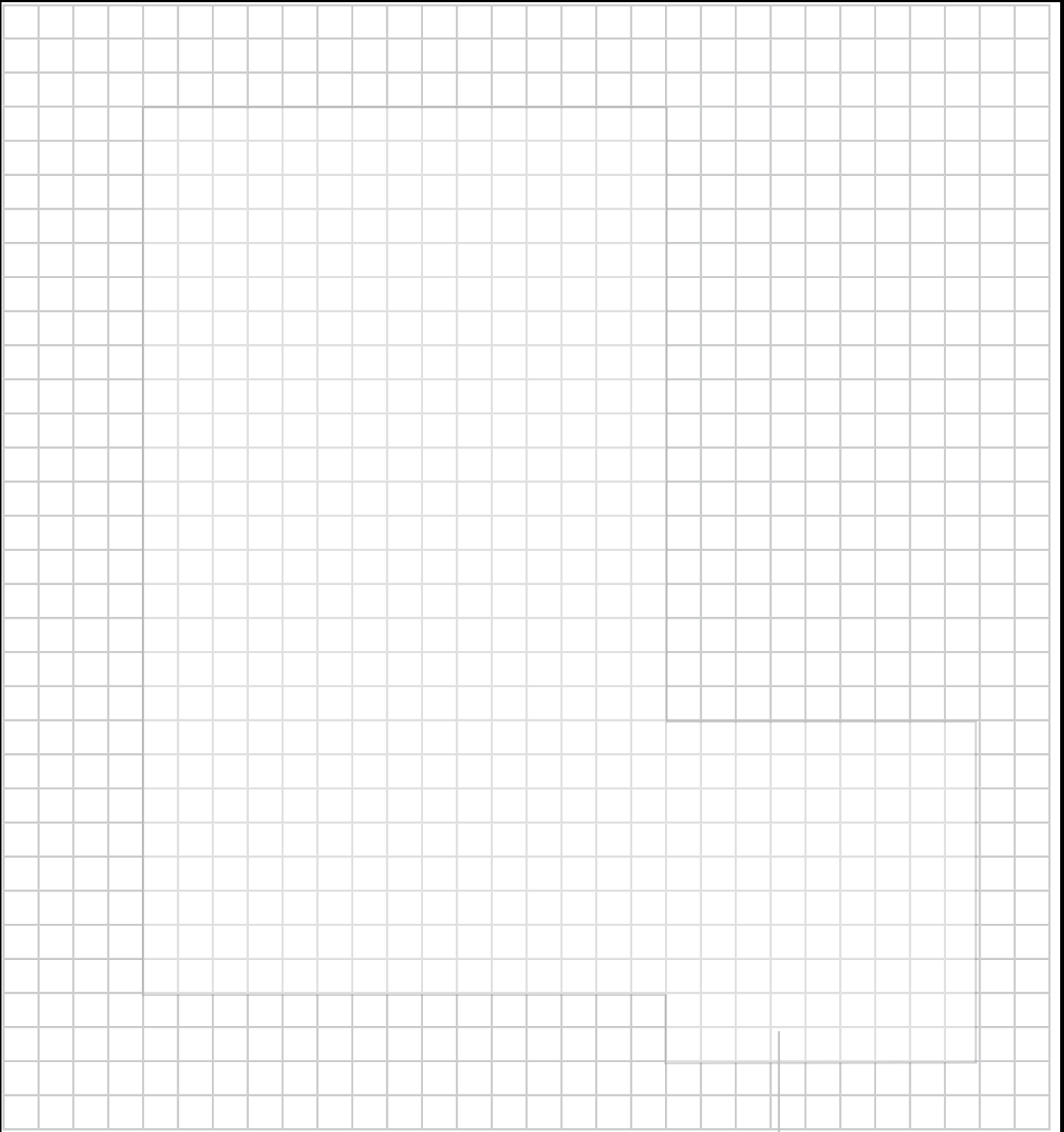

eg each square = 0.5m  
13m x 7.5m + 4.5m x 5m

Use this grid to help plan your outdoor space. Each square can represent 0.5m<sup>2</sup> or 1m<sup>2</sup> depending on the size of the space. Please consult your Supernatural Grass stockist for further details on product size and requirements.



## Laying Pavers - Step Three

### Select a Pattern

There are many pattern styles from which to choose when laying your pavers. Select from the patterns shown here or add your own special features. Each pattern shown is graded for difficulty and number of cuts. The higher the difficulty and a number of cuts, the greater the skill required and the greater the importance of the accuracy of planning and set out.



45° Herringbone •••

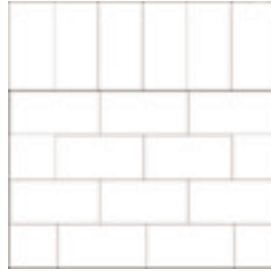

45° Stretcher Bond with Header course ••

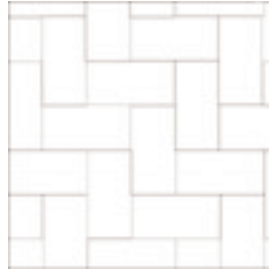

90° Herringbone •••

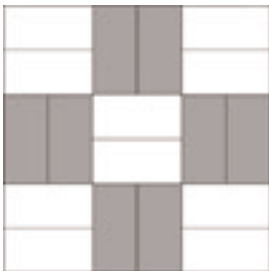

Basketweave ••

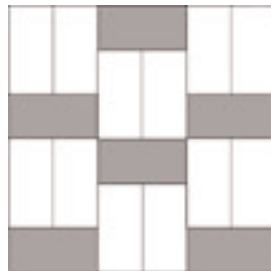

Half Basketweave ••



45° Stack Bond ••

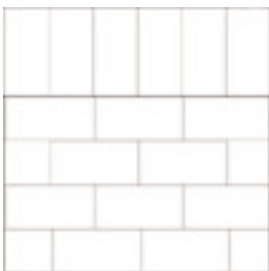

Stretcher Bond with Header course ••

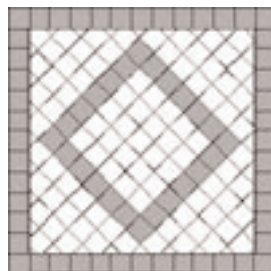

Diamond •

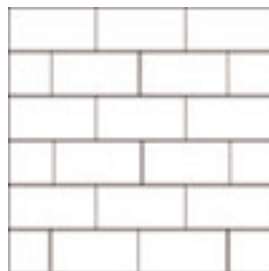

Stretcher Bond •

- **Beginner** minimum design skill and low number of paver cuts
- **Intermediate** some design and set out skill required. Moderate to high number of paver cuts
- **Advanced** high preparation and set out, also a large number of paver cuts

NOTE - It is recommended that the 45° or 90° Herringbone pattern be used for driveways.

## Laying Pavers - Step Four

### Calculate Your Requirements

#### Area

Calculate the area to be paved in square metres. The quantity of pavers needed will depend on the area to be paved, see figure 2 for tips calculating the paving area. This can be determined from the measurements taken from the site. This area is simply calculated by (m = metres): Allow up to 10% extra pavers for wastage such as cuts and breakage's etc. Pavers - Calculate the quantity of pavers required (see manufacturers guide to pavers per square metre)

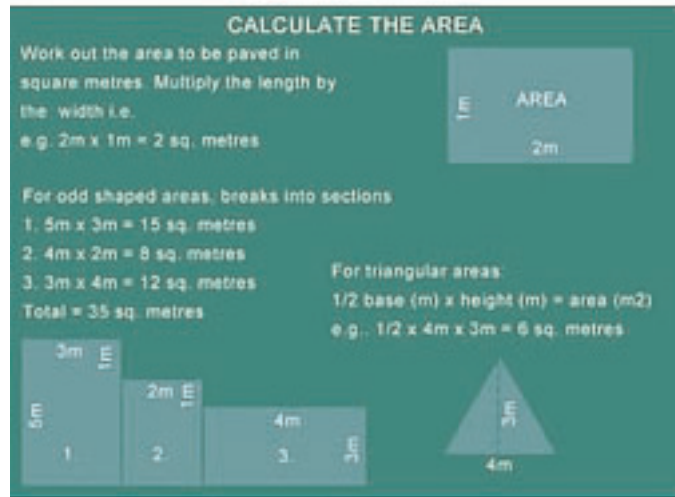

Figure 2

#### Road Base

How much ROAD BASE will you need?

For a strong foundation, your paving may need road base. If you are paving a driveway or on an unstable site, it is recommended that you consult a suitably qualified engineer. Generally, road base is layed to a total depth of 100 to 150mm (10-15cm) around the entire area.

For driveways, compact for every 50mm (5cm) layer and for pathways compact for every 60mm (6cm) layer.

For 10m<sup>2</sup> compacted to 100mm (10cm) you will need 1 cubic metres

For 10m<sup>2</sup> compacted to 50mm (5cm) you will need 0.5 cubic metres.

#### Bedding Sand

Bedding sand is used to provide the pavers with a medium that they can bed down into and form a firm position.

How much BEDDING SAND will you need? After the road base you will need to lay bedding sand evenly to a depth of 30mm (3cm) over the entire area. For 10m<sup>2</sup> compacted to a depth of 30mm (3cm) you will need 0.3 cubic metres. Bedding sand needs to be spread evenly over the paving area to a depth of 30mm

#### Joint Filling Sand

Used to fill the spaces between the pavers and fix them in place. How much PAVER JOINT FILLING SAND will you need? When laying pavers on the bedding sand it is recommended that a 2-3 mm gap is left between pavers. Then joint fill sand can be swept into the gaps. For 20-30m<sup>2</sup> of paving, leaving 2-3mm gaps you will need approximately 1 bag (10-20kg)

## Sand Cement Mix

Used to make edge restraints for the paved area if required. How much SAND CEMENT MIX will you need? Sand cement edge restraints may be needed to keep all the pavers from shifting. They can be made with a mixture of sand and cement. For 200 lineal metres of restraint you will need approximately 1 cubic metre of sand and cement mix. Refer to your local supplier (e.g. hardware store) for pre-bagged sand and cement mixes

## Laying Pavers - Step Five

### The Right Equipment

Use our Check List at the Start of the Steps to make sure you have all the right equipment.

## Laying Pavers - Step Six

### Preparing the Site

When determining your finished paved surface level remember to consider the following: Paving must slope away from the building; Allow for the depth of the base layer, bedding sand and paver figure 3.



Figure 3

Pavers should be flushed with the lawn. Excavate the area to be paved: Check the level and depth of the base by measuring from a string line (see figure 4) This depth should allow for the base layer, bedding sand and paver. Refer to figure 3 for approximate depths. Ensure the ground level is even. Replace wet patches, loose or soft areas with sand cement mix or compacted road base to create a stable base.



Figure 4

It is essential that rain water flow off the paving and away from buildings. To ensure this paving must not be completely flat, it should slope about 20mm (2cm) per metre. If the paving is against the side of a building, the pavers need to be a minimum of 25mm (2.5cm) below the damp proof course to prevent rising damp problems in your home. The damp proof course and air vents should never be covered. Pavers to come to this level when compacted prepare the ground to this line (parallel to string line) figure 4.

## Laying Pavers - Step Seven

### Laying the Base

Spread the base layer (Generally: road base material or well graded crushed rock) evenly over the prepared ground. Rake to an even thickness before compaction. Compaction of road base is usually performed using a mechanical plate compactor (see figure 5) It is recommended that the road base is compacted in 2-3 layers, not in one single layer. An uneven base will give an uneven paver surface. Check with a spirit level. When paving driveways or unstable sites, it is recommended that you consult a suitably qualified engineer.

## Laying Pavers - Step Eight

### The Bedding Layer

Spread and screed a coarse, well graded washed river sand. The easiest way to screed sand flat is to use two guides (screeding rails) and a screeding board. Place screeding rails in position and spread a layer of bedding sand over the rails. Pull the screeding board over the screeding rails to obtain a uniform depth of approximately 30mm (3cm). When the sand is screeded remove the guides and fill in the tracks with bedding sand and smooth off. Crusher dust and mixing sand with cement are not recommended for the bedding layer.



## Laying Pavers - Step Nine

### Laying the Pavers

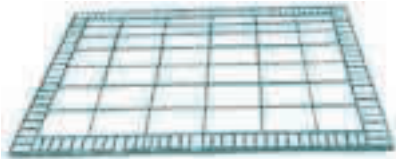

Figure 7



Figure 8

Setting out -The best way to ensure your paving pattern stays in line is to use set out lines. Use a grid of string lines spaced at exact intervals around the perimeter of the job (See figure 7) Use two string lines at right angles to keep the paving joints straight. When setting up the grid remember to add 2-3 mm to each paver width to allow for the gap between each unit. Place the pavers gently on the sand bed leaving a gap of 2-3mm between each unit, unless the pavers have nibs (this prevents chipping). Disturb the bed of sand as little as possible, you may stand on the pavers already laid but be careful not to stand on the leading row of pavers as they may tilt and shift the flat sand.

Select the pavers down the side of the pallets and randomly form different pallets to ensure an all over blend. For paving ideas, refer to the paving patterns step 3 To cut pavers a bolster can be used (see figure 8) or hire a paver splitter or a brick saw. For clay pavers it is necessary to use a diamond tipped blade and brick saw Edge restraints prevent the pavers from moving horizontally and also restrain the sand and road base (see figure 9a and 9b for possible options for edge restraints). For final compaction, the restraints should be approximately 10mm (1cm) below the pavers before compaction.



Figure 9a



Figure 9b

Edge restraint - sand cement wedge

Edge restraint - paving unit laid in end

Edge restraints can be made of treated timber, concrete (essential for driveways) or a paving unit on its side

## Laying Pavers - Step Ten

### Filling the Joints

Once the pavers are laid, sweep dry fine graded sand over the paved area ensuring that all joints are full. Do not mix cement with the jointing sand or the pavers may be stained.

## Laying Pavers - Step Eleven



**Figure 10**

### Compacting the Pavers

To secure the paving in place, compact the pavers using a mechanical plate compactor with a piece of carpet or rubber mat under the compactor to prevent the pavers from being scratched or damaged. After each pass of the compactor sweep in more jointing sand and compact again before sweeping off excess sand (see figure 10) For small areas pavers can be compacted by using a rubber mallet and a hardwood plank (see figure 11) For driveways it is recommended that a minimum of 3 passes are carried out with a mechanical plate compactor. Paving should generally compact approximately 10mm (1cm).



**Figure 11**

Then simply sit back, relax and enjoy the benefits of your handiwork; a new landscaped home that is all that you imagined it to be.

## Laying Pavers - Step Twelve

### Handy Paving Tips

If you're having trouble growing grass in heavy traffic areas consider a paved garden path. To minimise future maintenance consider a paving sealant. Melbourne Brick recommend the MSEAL range of sealers and cleaners which are tried, tested and proven for this type of paver. When paving against a house remember to have effective white ant/termite protection. Always remember to include a 2-3 mm gap between each paver when laying. When paving against a house it is recommended that the top of paving is a minimum of 25mm (2.5cm) below the damp proof course. It is also advisable to place a plastic membrane against the exposed concrete of the house footing. When paving a slope, it is important to start at the bottom and pave up the slope.

### Selecting a Contractor

If you feel that laying your own paving is not for you, then experienced contractors are available to complete your work. It is recommended that you use only an accredited paviour. When selecting a contractor, it is advisable to obtain a minimum of 3 quotations, itemising the exact work quoted for. Inspect previous work and contact customers if possible to ensure the contractor is capable of providing the finish you require. NOTE: Certain situations and applications (such as unstable ground and poor drainage areas) may require your paving to be designed by a suitably qualified engineer.

### Cleaning and Maintenance

A carefully planned maintenance program is the best method to keep Melbourne Brick pavers looking good for years to come. Simple steps should include: Regular sweeping to keep the pavers free from debris; Hosing down the pavement at regular intervals to stop the build up of dust, grime and pollution; During construction, cover the paved areas to protect against damage; Protecting against possible staining from mortar, oxides, cement and rust; Do not use acid to clean pavers; Do not use a high pressure cleaning apparatus. Prior to removing stains, we suggest that the type of stain be carefully assessed before action proceeds. Incorrect assessment can lead to the stain being more difficult to remove. If the stain cannot be accurately assessed, then we would recommend that a trial process on a small portion of the stained area be undertaken to determine the most appropriate action.

### Efflorescence

Do not hose the salt deposit with water. Brush with a stiff bristled broom, or sprinkle slightly damp sand over the area, then brush away and hose gently with water.

### Moss

Brush the affected area when dry. Or soak the area with a solution 10 parts water with one part vinegar. Leave for 10 minutes then gently hose down before the solution dries. For more information on cleaning and maintenance, please see additional Melbourne Brick brochures. Do not use acids to remove stains under any circumstances. This is the last step in the Laying Pavers easy planner guide.

Thankyou